

BUSH HOG®

MODEL RTC Rotary Tiller

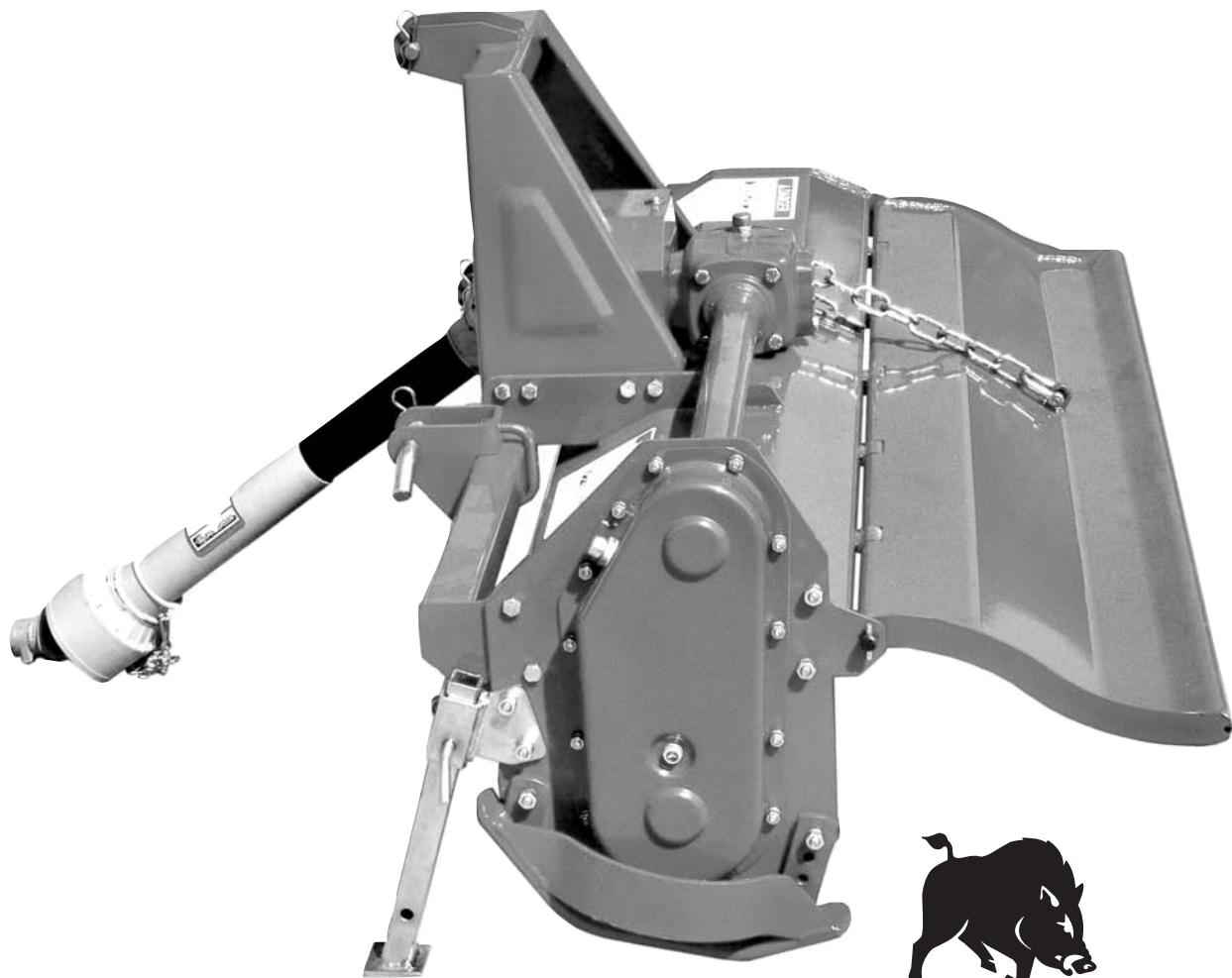

BUSH HOG®
Performance You Can Count OnSM

ASSEMBLY ● OPERATION ● MAINTENANCE

CONGRATULATIONS!

You have invested in the best implement of its type on the market today.

The care you give your Bush Hog implement will greatly determine your satisfaction with its performance and its service life. We urge a careful study of this manual to provide you with a thorough understanding of your new implement before operating, as well as suggestions for operation and maintenance.

If your manual should become lost or destroyed, Bush Hog will be glad to provide you with a new copy. Order from Bush Hog, P. O. Box 1039, Selma, Alabama 36702-1039. Most of our manuals can also be downloaded from our website at www.bushhog.com.

As an authorized Bush Hog dealer, we stock genuine Bush Hog parts which are manufactured with the same precision and skill as our original equipment. Our trained service personnel are well informed on methods required to service Bush Hog equipment, and are ready and able to help you.

Should you require additional information or assistance, please contact us.

YOUR AUTHORIZED
BUSH HOG DEALER

BECAUSE BUSH HOG MAINTAINS AN ONGOING PROGRAM OF PRODUCT IMPROVEMENT, WE RESERVE THE RIGHT TO MAKE IMPROVEMENTS IN DESIGN OR CHANGES IN SPECIFICATIONS WITHOUT INCURRING ANY OBLIGATION TO INSTALL THEM ON UNITS PREVIOUSLY SOLD.

BECAUSE OF THE POSSIBILITY THAT SOME PHOTOGRAPHS IN THIS MANUAL WERE TAKEN OF PROTOTYPE MODELS, PRODUCTION MODELS MAY VARY IN SOME DETAIL. IN ADDITION, SOME PHOTOGRAPHS MAY SHOW SHIELDS REMOVED FOR PURPOSES OF CLARITY. **NEVER OPERATE THIS IMPLEMENT WITHOUT ALL SHIELDS IN PLACE.**

Model RTC

Rotary Tiller Operator's Manual

TABLE OF CONTENTS

SECTION / PARA	PAGE	SECTION / PARA	PAGE
Warranty	2	3-3 Operation	9
Dealer Preparation Check List	3	3-4 Transporting	9
Safety Precautions	4		
Federal Laws And Regulations	5	IV MAINTENANCE	10
I INTRODUCTION & DESCRIPTION ...	6	4-1 Maintenance Check List	10
1-1 Introduction	6	4-2 Lubrication	10
1-2 Description	6	4-3 Blade Replacement	12
II PREPARATION FOR USE	7	4-4 Slip Clutch Operational Check ...	12
2-1 Attaching To Tractor	7	4-5 Slip Clutch Adjustment	12
III OPERATING INSTRUCTIONS	9	4-7 Troubleshooting	13
3-1 General Safety	9	V DEALER ASSEMBLY	14
3-2 Adjusting For Work	9	Safety Decals	16
		Torque Specifications	17

RETAIL CUSTOMER'S RESPONSIBILITY UNDER THE BUSH HOG WARRANTY

It is the Retail Customer and/or Operator's responsibility to read the Operator's Manual, to operate, lubricate, maintain and store the product in accordance with all instructions and safety procedures. Failure of the operator to read the Operator's Manual is a misuse of this equipment.

It is the Retail Customer and/or Operator's responsibility to inspect the product and to have any part(s) repaired or replaced when continued operation would cause damage or excessive wear to other parts or cause a safety hazard.

It is the Retail Customer's responsibility to deliver the product to the authorized Bush Hog Dealer, from whom he purchased it, for service or replacement of defective parts which are covered by warranty. Repairs to be submitted for warranty consideration must be made within forty-five (45) days of failure.

It is the Retail Customer's responsibility for any cost incurred by the Dealer for traveling to or hauling of the product for the purpose of performing a warranty obligation or inspection.



BUSH HOG®
Performance You Can Count OnSM

LIMITED WARRANTY



Bush Hog warrants to the original purchaser of any new Bush Hog equipment, purchased from an authorized Bush Hog dealer, that the equipment be free from defects in material and workmanship for a period of one (1) year for non-commercial, state, and municipalities' use and ninety (90) days for commercial use from date of retail sale. The obligation of Bush Hog to the purchaser under this warranty is limited to the repair or replacement of defective parts.

Replacement or repair parts installed in the equipment covered by this limited warranty are warranted for ninety (90) days from the date of purchase of such part or to the expiration of the applicable new equipment warranty period, whichever occurs later. Warranted parts shall be provided at no cost to the user at an authorized Bush Hog dealer during regular working hours. Bush Hog reserves the right to inspect any equipment or parts which are claimed to have been defective in material or workmanship.

DISCLAIMER OF IMPLIED WARRANTIES & CONSEQUENTIAL DAMAGES

Bush Hog's obligation under this limited warranty, to the extent allowed by law, is in lieu of all warranties, implied or expressed, **INCLUDING IMPLIED WARRANTIES OF MERCHANTABILITY AND FITNESS FOR A PARTICULAR PURPOSE** and any liability for incidental and consequential damages with respect to the sale or use of the items warranted. Such incidental and consequential damages shall include but not be limited to: transportation charges other than normal freight charges; cost of installation other than cost approved by Bush Hog; duty; taxes; charges for normal service or adjustment; loss of crops or any other loss of income; rental of substitute equipment, expenses due to loss, damage, detention or delay in the delivery of equipment or parts resulting from acts beyond the control of Bush Hog.

THIS LIMITED WARRANTY SHALL NOT APPLY:

1. To vendor items which carry their own warranties, such as engines, tires, and tubes.
2. If the unit has been subjected to misapplication, abuse, misuse, negligence, fire or other accident.
3. If parts not made or supplied by Bush Hog have been used in connection with the unit, if, in the sole judgement of Bush Hog such use affects its performance, stability or reliability.
4. If the unit has been altered or repaired outside of an authorized Bush Hog dealership in a manner which, in the sole judgement of Bush Hog, affects its performance, stability or reliability.
5. To normal maintenance service and normal replacement items such as gearbox lubricant, hydraulic fluid, worn blades, or to normal deterioration of such things as belts and exterior finish due to use or exposure.
6. To expendable or wear items such as teeth, chains, sprockets, belts, springs and any other items that in the company's sole judgement is a wear item.

NO EMPLOYEE OR REPRESENTATIVE OF BUSH HOG IS AUTHORIZED TO CHANGE THIS LIMITED WARRANTY IN ANY WAY OR GRANT ANY OTHER WARRANTY UNLESS SUCH CHANGE IS MADE IN WRITING AND SIGNED BY BUSH HOG'S SERVICE MANAGER, POST OFFICE BOX 1039, SELMA, ALABAMA 36702-1039.



Record the model number, serial number and date purchased. This information will be helpful to your dealer if parts or service are required.

MODEL NUMBER _____

SERIAL NUMBER _____

MAKE CERTAIN THE WARRANTY REGISTRATION CARD HAS BEEN FILED WITH BUSH HOG/ SELMA, ALABAMA

DATE OF RETAIL SALE _____

DEALER PREPARATION CHECK LIST

ROTARY TILLERS

BEFORE DELIVERING MACHINE — The following check list should be completed.
Use the Operator's Manual as a guide.

- 1. Assembly completed.
- 2. Gearboxes filled with oil.
- 3. All fittings lubricated.
- 4. All shields in place and in good condition.
- 5. All fasteners torqued to specifications given in Torque Chart.
- 6. Slip clutch checked for proper operation.
- 7. All decals in place and readable. (See decal page.)
- 8. Overall condition good (i.e. paint, welds)
- 9. Operator's manual has been delivered to owner and he has been instructed on the safe and proper use of the cutter.

Dealer's Signature _____

Purchaser's Signature _____

THIS CHECKLIST TO REMAIN IN OWNER'S MANUAL

It is the responsibility of the dealer to complete the procedures listed above before delivery of this implement to the customer.

IMPORTANT SAFETY PRECAUTIONS

This symbol is used to call attention to safety precautions that should be followed by the operator to avoid accidents. When you see this symbol, carefully read the message that follows and heed its advice. Failure to comply with safety precautions could result in serious bodily injury.



In addition to the design and configuration of equipment, hazard control and accident prevention are dependent upon the awareness, concern, prudence and proper training of personnel in the operation, transport, maintenance and storage of equipment. Lack of attention to safety can result in accident, personal injury, reduction of efficiency and worst of all—loss of life. Watch for safety hazards and correct deficiencies promptly. Use the following safety precautions as a general guide to safe operations when using this machine. Additional safety precautions are used throughout this manual for specific operating and maintenance procedures. Read this manual and review the safety precautions often until you know the limitations.

1. Read the Operator's Manual. Failure to read the Operator's Manual is considered a misuse of this equipment.
2. Become familiar with all the machine's controls and all the caution, warning and danger decals affixed to the machine before attempting to start or operate.
3. Before starting or operating the machine, make a walk around inspection and check for obvious defects such as loose mounting bolts and damaged components. Correct any deficiency before starting.
4. Do not allow children to operate the implement. Do not allow adults to operate it without proper instruction.
5. Do not carry passengers.
6. Keep the area of operation clear of all persons, particularly small children and pets. The operator should cease operation whenever anyone comes within the area.
7. Lower implement to ground, stop tractor engine and apply parking brake before leaving the tractor.
8. Keep hands and feet away from implement.
9. Wear personal protective equipment such as, but not limited to, protection for eyes, ears, feet, hands and head when operating or repairing the equipment. Do not wear loose clothing or jewelry that may catch on equipment moving parts.
10. When performing adjustments or maintenance on the implement, first lower it to the ground or block it securely at a workable height.
11. Never stand between tractor and implement while tractor is being backed to the hitch.
12. Reduce speed when transporting implement to avoid bouncing and momentary loss of steering.
13. Use tractor flashing warning lights, day or night, when transporting implement on road or highways unless prohibited by law.
14. Use a rollover protective structure and seat belt equipped tractor for all implement operations.

IMPORTANT FEDERAL LAWS AND REGULATIONS* CONCERNING EMPLOYERS, EMPLOYEES AND OPERATIONS.

*(This section is intended to explain in broad terms the concept and effect of the following federal laws and regulations. It is not intended as a legal interpretation of the laws and should not be considered as such).

U.S. Public Law 91-596 (The Williams-Steiger Occupational and Health Act of 1970) OSHA

This Act Seeks:

“...to assure so far as possible every working man and woman in the nation safe and healthful working conditions and to preserve our human resources...”

DUTIES

Sec. 5 (a) Each employer—

- (1) shall furnish to each of his employees employment and a place of employment which are free from recognized hazards that are causing or are likely to cause death or serious physical harm to his employees;
- (2) shall comply with occupational safety and health standards promulgated under this Act.

(b) Each employee shall comply with occupational safety and health standards and all rules, regulations and orders issued pursuant to this Act which are applicable to his own actions and conduct.

OSHA Regulations

Current OSHA regulations state in part: “At the time of initial assignment and at least annually thereafter, the employer shall instruct every employee in the safe operation and servicing of all equipment with which the employee is, or will be involved.” These will include (but are not limited to) instructions to:

Keep all guards in place when the machine is in operation;

Permit no riders on equipment;

Stop engine, disconnect the power source, and wait for all machine movement to stop before servicing, adjusting, cleaning or unclogging the equipment, except where the machine must be running to be properly serviced or maintained, in which case the employer shall instruct employees as to all steps and procedures which are necessary to safely service or maintain the equipment.

Make sure everyone is clear of machinery before starting the engine, engaging power, or operating the machine.

EMPLOYEE TRACTOR OPERATING INSTRUCTIONS:

1. Securely fasten your seat belt if the tractor has a ROPS.
2. Where possible, avoid operating the tractor near ditches, embankments, and holes.
3. Reduce speed when turning, crossing slopes, and on rough, slick, or muddy surfaces.
4. Stay off slopes too steep for safe operation.
5. Watch where you are going, especially at row ends, on roads, and around trees.
6. Do not permit others to ride.
7. Operate the tractor smoothly - no jerky turns, starts, or stops.
8. Hitch only to the drawbar and hitch points recommended by tractor manufacturers.
9. When tractor is stopped, set brakes securely and use park lock if available.

Child Labor Under 16 Years Old

Some regulations specify that no one under the age of 16 may operate power machinery. It is your responsibility to know what these regulations are in your own area or situation. (Refer to U.S. Dept. of Labor, Employment Standard Administration, Wage & Home Division, Child Labor Bulletin #102.)

SECTION I

INTRODUCTION AND DESCRIPTION

1-1 INTRODUCTION

We are pleased to have you as a Bush Hog customer. Your Bush Hog Rotary Tiller has been carefully designed to give maximum service with minimum down time. This manual is provided to give you the necessary operating and maintenance instructions for keeping your rotary tiller in top operating condition. Please read this manual thoroughly. Understand what each control is for and how to use it. Observe all safety precautions decal on the machine and noted throughout the manual for safe operation of the implement. If any assistance or additional information is needed, contact your authorized Bush Hog dealer.

NOTE

All references made in this manual to right, left, front, rear, top and bottom is as viewed facing the direction of forward travel with implement properly attached to tractor.

1-2 DESCRIPTION

The RTC series of rotary tillers are intended for light duty use in an environment relatively clean of foreign objects such as large rocks, etc. Each tiller is equipped with adjustable skid shoes and rear deflector shield for setting the desired operating depth and tilth of soil. The drivetrain consists of a telescoping input driveshaft; 90 degree transfer gearbox, cross-shaft and chain drive rotor. Protection is provided by a slip clutch on the driveline. The chain is self-adjusted by a spring tension device. Major components are identified in Figure 1-1.

Figure 1-1 Major Components

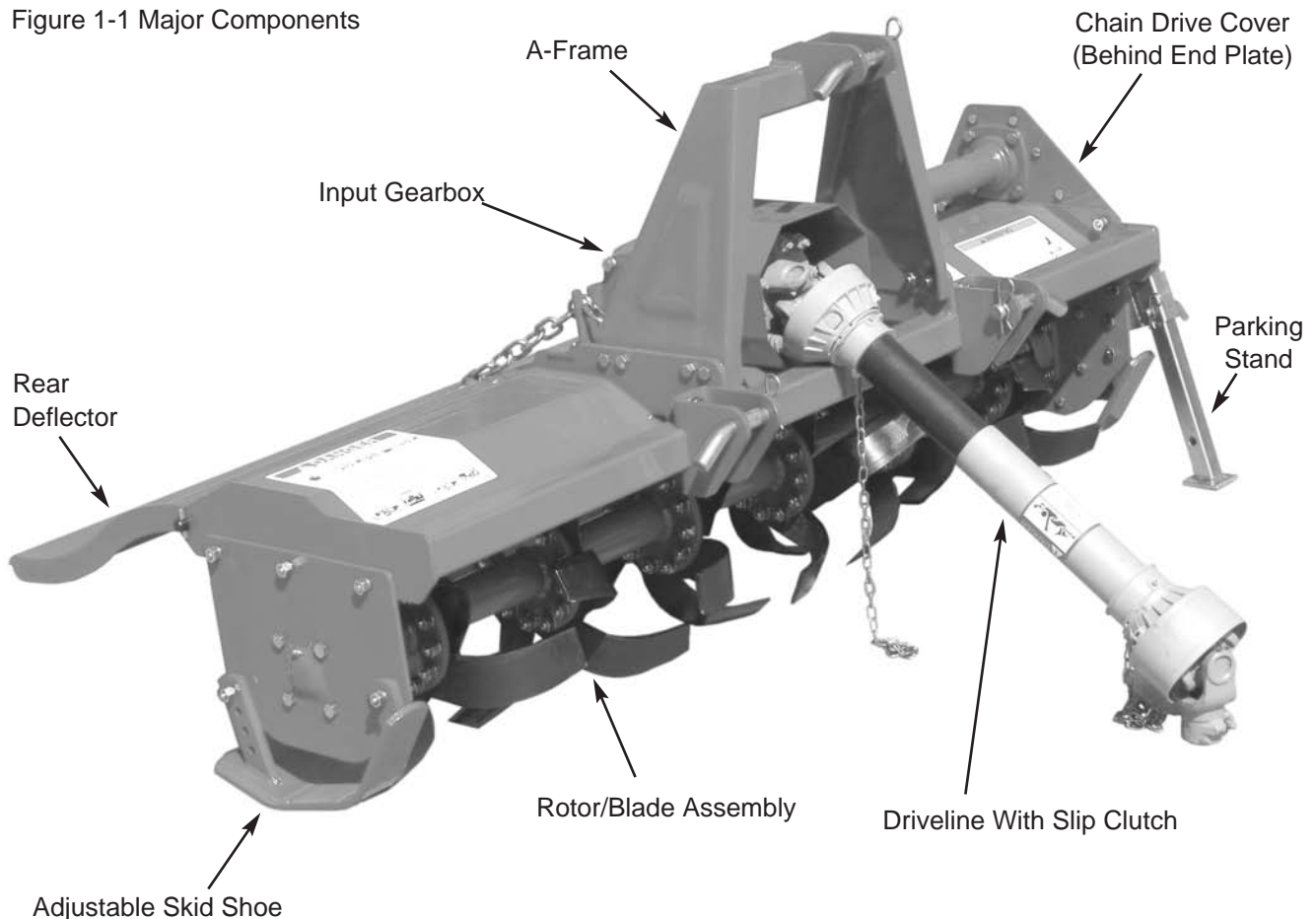

SPECIFICATIONS

	Model RTC40	Model RTC48
Tilling width	39-1/4"	48-1/4"
Overall width	44"	53"
Offset	4"	N/A
Blades per flange	4	4
No. of flanges	4	5
Hitch	3-point Cat. I only	
PTO speed	540 rpm	
Rotor speed	250 rpm	
Max. recommended HP	24	
Max. till depth	6"	
Gearbox oil capacity	17 ozs.	
Weight	308 lbs.	335 lbs.
Driveline protection	Slip Clutch	

SECTION II PREPARATION FOR USE

2-1 ATTACHING TO TRACTOR

⚠ WARNING

TO AVOID SERIOUS INJURY OR DEATH: NEVER STAND BETWEEN TRACTOR AND TILLER WHILE TRACTOR IS BEING BACKED TO HITCH.

⚠ WARNING

TO AVOID SERIOUS INJURY OR DEATH: ADDITIONAL TRACTOR FRONT BALLAST MAY BE NEEDED FOR STABLE OPERATION AND TRANSPORT OF THE TILLER. SEE TRACTOR OPERATOR'S MANUAL FOR RECOMMENDED WEIGHTS.

A. Attach tiller to tractor 3-point hitch per tractor operator's manual. Do not attach driveline at this time.

NOTE

Due to the many variations in tractor/implement hitch points and corresponding differences in distances between tractor PTO shafts and implement input shafts, drivelines may need to be shortened as described in the following steps:

B. Raise and lower tiller to determine position with shortest distance between the tractor PTO shaft and gearbox input shaft. Shut down tractor, leaving tiller in position of shortest distance. **Securely block tiller in position.**

C. Pull driveline apart. Attach outer (female) section to tractor PTO shaft. Pull on driveline section to be sure that yoke locks into place.

D. Hold driveline sections parallel to each other to determine if it is too long. Each section should end approximately 3 inches (76mm) short of reaching universal joint shield on opposite section. If too long, measure 3 inches back from universal joint shield and mark on opposite section. (Figure 2-1). Do this for both sections.

Figure 2-1

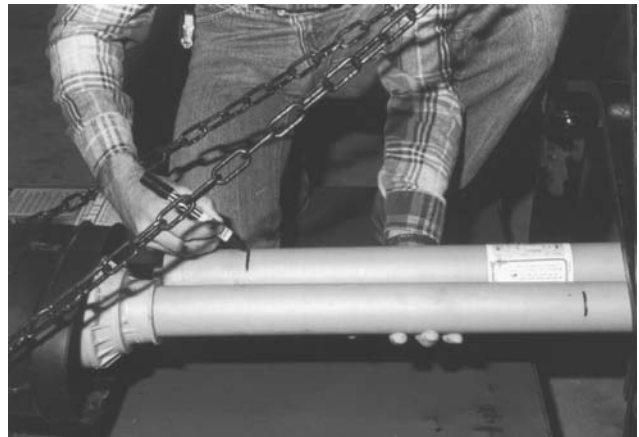

E. Raise and lower tiller to determine position with greatest distance between PTO shaft and gearbox input shaft. Shut down tractor leaving tiller in position of greatest distance. **Securely block tiller in position.**

F. Hold driveline sections parallel to each other and check for minimum 6 inches (15cm) overlap. (Figure 2-2) If driveline has been marked for cutting, overlap will be the distance between two marks. If driveline has less than minimum overlap, do not use. Contact authorized Bush Hog dealer.

Figure 2-2

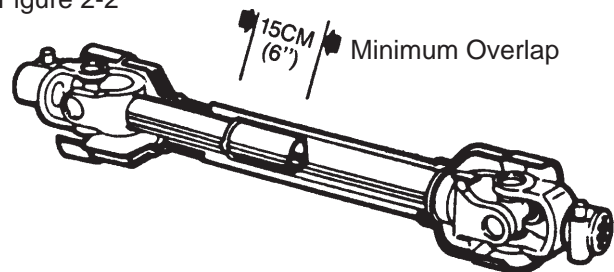

NOTE

If driveline is the correct length, omit the following steps "G" through "J" and proceed to step "K".

G. Clamp driveline in a well padded vice to prevent damage to the shield. Cut off shield where marked. (Figure 2-3)

Figure 2-3



H. Using cut off section of shield as a guide, cut shaft the same amount. (Figure 2-4)

Figure 2-4



I. Repeat steps "G" and "H" to other driveline section.

J. Deburr ends of driveline sections and clean away all chips and fillings. (Figure 2-5)

K. Apply multi-purpose grease to inside of outer (female) driveline section. Assemble driveline and install on tractor and tiller. Pull on each driveline section to be sure yokes lock into place. Make certain driveline shielding is in place and in good condition.

⚠ DANGER

MAKE CERTAIN DRIVELINE YOKES ARE SECURELY FASTENED. FAILURE TO DO SO MAY RESULT IN SERIOUS INJURY.

Figure 2-5



L. Adjust lower lift arm to level tiller right to left. Refer to tractor operator's manual for instructions.

M. Adjust top link of tractor 3-point hitch to level tiller front to rear.

N. Set up tractor stabilizer bars, sway blocks, or equivalent to prevent implement side sway. (Figure 2-6)

Figure 2-6

Stabilizer Bars

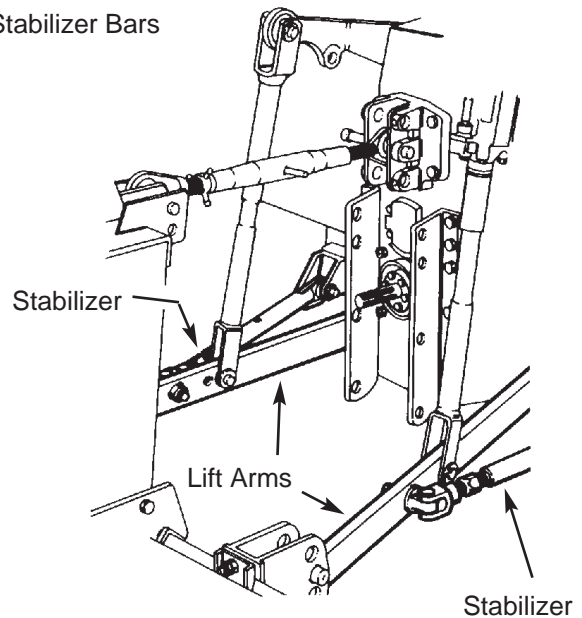

SECTION III OPERATING INSTRUCTIONS

3-1 GENERAL SAFETY

Only qualified people familiar with this operator's manual should operate this machine. Operator should wear hard hat, safety glasses, and safety shoes. The operator should read, understand and practice all safety messages shown on the caution, warning, and danger decals affixed to the tiller to avoid serious injury or death. Use a rollover protective structure and seatbelt equipped tractor for all operations. Before beginning operation, clear work area of objects that may be picked up and thrown or wrapped in tiller blades. Check for ditches, stumps, holes, or other obstacles that could upset tractor or damage tiller. Always turn off tractor engine, set parking brake, and allow rotor to come to a complete stop before dismounting tractor.

3-2 ADJUSTING FOR WORK

! WARNING

THE TILLER CAN FALL FROM HYDRAULIC SYSTEM FAILURE. TO AVOID SERIOUS INJURY OR DEATH, SECURELY SUPPORT TILLER BEFORE WORKING UNDERNEATH.

Depth of till is regulated by adjusting skids up or down. (Figure 3-1) Average soil with reasonable moisture will allow maximum depth in one pass with a tractor forward speed up to 2 mph. Hard soil may require two passes to reach maximum depth.

Figure 3-1 Adjustments

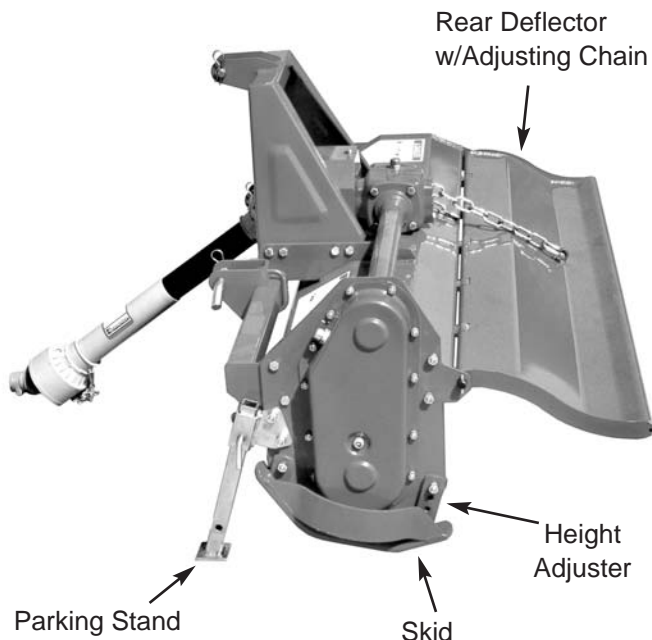

Tractor forward speed and rear shield adjustment (Figure 3-1) will regulate the finished results or tith of soil. Traveling at the slowest forward speed with rear deflector fully lowered will give finest possible finish. This deflector adjustment is good for mulching, mixing, and burying weeds, fertilizer, etc. The more you increase forward speed and deflector height, the coarser the finished results will be. To leave the ground surface rough with larger clods and residue exposed, work with deflector fully raised. When working in rocky soil, always have shield in raised position.

3-3 OPERATION

- Perform BEFORE EACH USE maintenance listed in paragraph 4-1.
- Adjust for work per paragraph 3-2.
- Start tractor. Raise tiller off the ground.
- With tractor at idle speed, engage PTO drive.

! DANGER

STAY CLEAR OF ROTATING DRIVELINES. DO NOT OPERATE WITHOUT DRIVELINE SHIELDS IN PLACE AND IN GOOD CONDITION. FAILURE TO HEED THESE WARNINGS MAY RESULT IN PERSONAL INJURY OR DEATH.

! DANGER

KEEP HANDS AND FEET FROM UNDER MACHINE AT ALL TIMES. MAKE CERTAIN EVERYONE IS CLEAR OF MACHINE BEFORE OPERATING. FAILURE TO HEED THESE WARNINGS MAY RESULT IN PERSONAL INJURY OR DEATH.

E. Place tractor in gear and proceed forward. Increase speed to 3/4 throttle. Lower tiller into soil. Increase speed to 540 PTO rpm. Average soil with reasonable moisture will allow travel speeds up to 2 mph. Hard soil will require low travel speed, less than 1 mph to ensure smooth operation and maximum possible depth. Shallow weed cultivation will allow speeds up to 3 mph. At the end of a pass lift tiller clear of ground before making a turn. After turning, proceed back across field, slowly lowering the tiller into the soil. **Do not turn with tiller in the ground as this can damage tiller and tractor linkage. Never use reverse gear while tiller is lowered into ground. Avoid operating tiller in the raised position.**

3-4 TRANSPORTING

Do not engage PTO drive while transporting tiller. Obey all state and local laws when transporting on public roads. Always use flashing warning lights unless prohibited by law.

SECTION IV MAINTENANCE

4-1 MAINTENANCE CHECK LIST

Perform scheduled maintenance as outlined below. Lower machine to ground, turn off tractor and set parking brake before doing maintenance inspections or work. Some checks may require raising machine off ground and supporting with blocks. All bolts should be torqued as recommended in TORQUE SPECIFICATIONS, unless otherwise indicated.

BEFORE EACH USE

1. Check tractor tire air pressure. Refer to tractor operator's manual.

WARNING

THE TILLER CAN FALL FROM HYDRAULIC SYSTEM FAILURE. TO AVOID SERIOUS INJURY OR DEATH, SECURELY SUPPORT TILLER BEFORE WORKING UNDERNEATH.

2. Check blades and rotor to be sure that no foreign objects such as wire or steel strapping bands are wrapped around them.
3. Check blade bolts for tightness. Tighten to 70 ft./lbs.
4. Inspect blades for wear. Replace if necessary.
5. Make certain driveline shields are in place and in good repair.
6. Clean any debris from safety decals and check for legibility. Replace any missing or illegible decals. Read and heed safety messages.
7. Perform BEFORE EACH USE lubrication per paragraph 4-2.
8. During operation, listen for abnormal sounds which might indicate loose parts, damaged bearings, or other damage.

Figure 4-1
Lubrication
Chain Drive
Oil Filler Plug
(6) 50 Hours

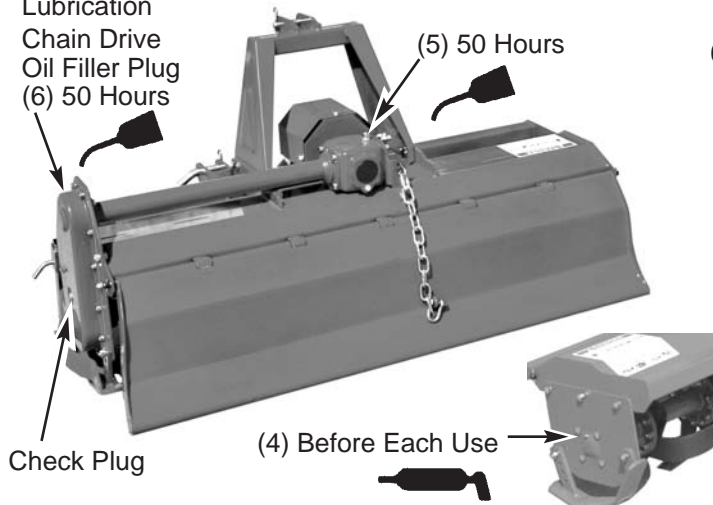

AFTER EACH USE

1. Clean all debris from machine especially underside of deck and affixed decals. Replace any missing or illegible decals.
2. Inspect tiller for worn or damaged components. Repair or replace before next use. Any replacement components installed during repair shall include the components current safety decals specified by the manufacturer to be affixed to the component.
3. Store in dry place.

4-2 LUBRICATION (Figure 4-1)

NOTE

The multi-purpose grease referenced in this section is an NLGI Grade 2 type grease.

BEFORE EACH USE

1. Driveline Universal Joints - Apply multi-purpose grease with grease gun.
2. Driveline Guard - Apply 2-3 shots of multi-purpose grease with grease gun to plastic fitting.
3. Driveline - Disconnect PTO driveline, pull the two sections apart, apply thin coat of multi-purpose grease to inside of outer (female) section. Reassemble sections and install. Pull each section to be sure driveline and shields are securely connected. Make certain PTO shielding is in good condition.
4. Rotor Shaft Bearing - Apply 2-3 shots of multi-purpose grease with hand pump grease gun before each operation and before storage. (Figure 4-1)

50 HOURS

5. Input Gearbox - Add EP80W-90 gear oil, if necessary, to bring oil to correct level on dip stick.
6. Chain Drive - Add EP80W-90 gear oil, if necessary, to bring oil level to checkplug located on side of cover.

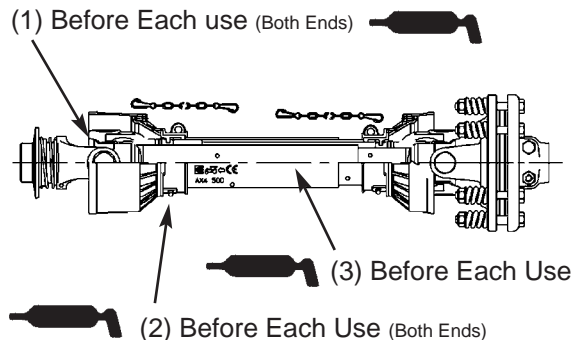

NOTE: In some instances, sliding the yoke shield back will make lubrication, inspection and cleaning of the universal joints more convenient. Proceed as follows:

1. Using a flat blade screwdriver, rotate the fastening pin in its seat 1/2 turn until the head of the pin becomes unlocked in its housing on the cones. (Figure 4-2)

Figure 4-2

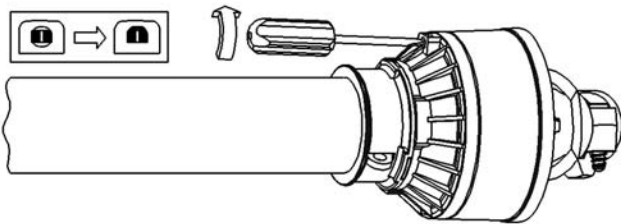

2. Lever up the pin through the slot, until the pin comes out. (Figure 4-3)

Figure 4-3

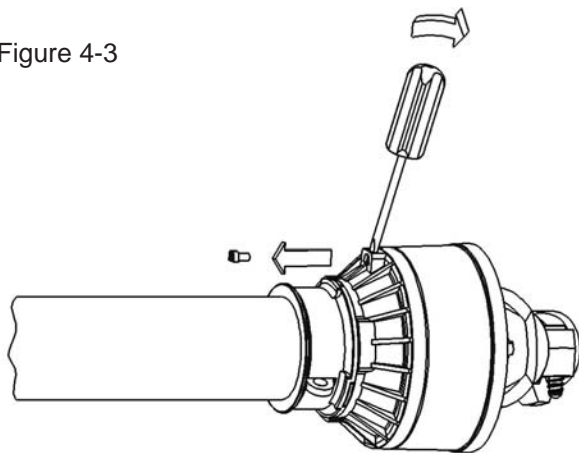

3. Rotate the soft cone until the slots are aligned with the corresponding ones of the rigid cone. (Figure 4-4)

Figure 4-4

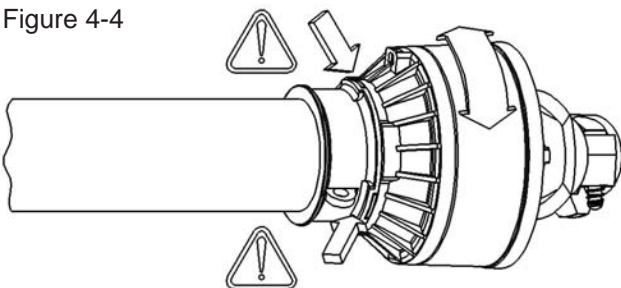

4. Remove the cones from the half-joint. (Figure 4-5)

Figure 4-5

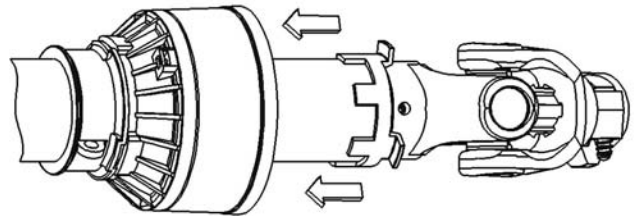

5. Remove the connecting ring from its housing on the yoke and, at the same time, from the slots of the guard tube, then move away the ring and the tube. (Figure 4-6)

Figure 4-6

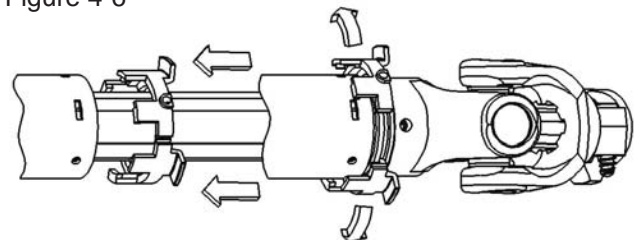

Reassembly is in the reverse order

4-3 BLADE REPLACEMENT

WARNING

THE TILLER CAN FALL FROM HYDRAULIC SYSTEM FAILURE. TO AVOID SERIOUS INJURY OR DEATH, SECURELY SUPPORT TILLER BEFORE WORKING UNDERNEATH.

Tiller blades should be replaced when they have approximately 1/4" of wear left on tip of blade. (Figure 4-7) To replace blades, remove bolts securing blade. Install new blade in its place. Blade must be a right or left corresponding to the blade removed. Pay special attention to the bolts on the blades; the bolt head must be placed on the blade side, with the washer and the nut on the flange side so that the bolts cannot loosen while the equipment is being used. When several blades must be replaced, replace one blade at a time, so that the initial layout is maintained. (Figure 4-8) **Tighten blade bolts to 70 ft. lbs.** Use only genuine Bush Hog replacement parts.

Figure 4-7

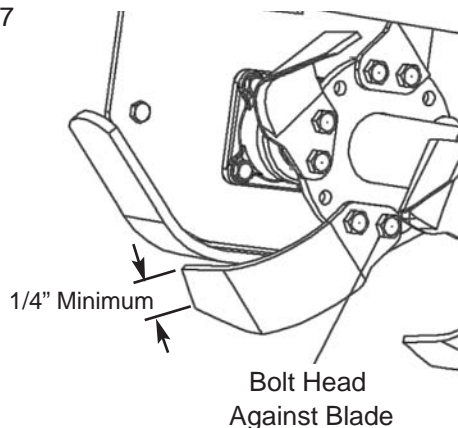
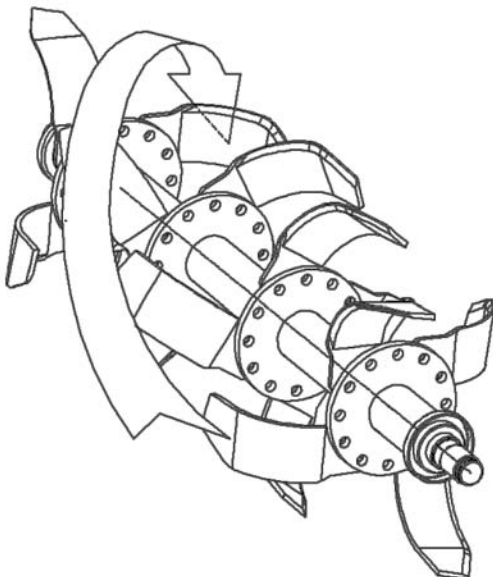

Figure 4-8
Helical Arrangement



4-4 SLIP CLUTCH OPERATIONAL CHECK

After tiller has been stored for 30 days or more, perform the following operational check:

A. Loosen eight nuts retaining clutch springs exactly one full turn.

B. With tiller blades firmly on ground and tractor at idle speed, engage tractor PTO drive for 2-3 seconds. Clutch should slip without turning blades. If clutch does not slip, contact your authorized Bush Hog dealer.

C. Retighten nuts to within 1/64" of original position. Initial spring length is 1-1/16" (27mm). (Figure 4-9)

CAUTION

FAILURE TO RETIGHTEN SPRING NUTS TO ORIGINAL POSITION MAY CAUSE DAMAGE TO TILLER AND/OR TRACTOR DUE TO IMPROPER SLIP CLUTCH TORQUE SETTING.

4-5 SLIP CLUTCH ADJUSTMENT

The slip clutch is factory preset to the correct torque for protecting implement and tractor. **Periodic adjustment is recommended**; refer to Section 4-4. Should adjustment be needed, first check to be sure all spring lengths are within 1/64" of being the same. Initial spring length is 1-1/16" (27mm) shown in Figure 4-9. If necessary, loosen nut on any spring that is unequal. Adjust all eight spring retaining nuts 2/3 of a turn (2 flats on a nut) and check clutch slippage. If further adjustment is necessary, do so in 1/3 turn increments or consult your Bush Hog dealer. Adjust only to provide sufficient torque to prevent slippage under normal conditions. When rocks, roots, etc. are present, occasional slippage is normal for drivetrain protection.

Figure 4-9
Clutch Spring Length

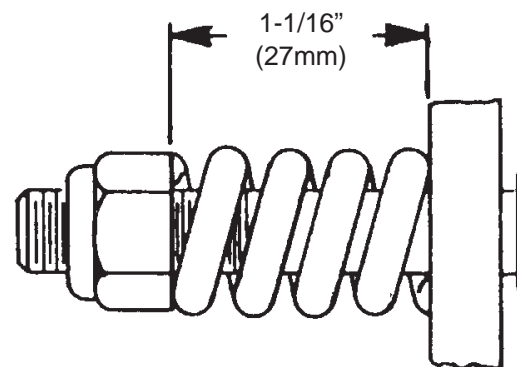

4-7 TROUBLESHOOTING

Troubleshooting procedures are listed in Table 4-1 below. If the problem cannot be solved or replaced,

ment parts are necessary, contact your authorized Bush Hog dealer. Please have ready your machine name, model number, serial number, purchase date, and exact cause or description of problem.

Table 4-1 Troubleshooting

PROBLEM	PROBABLE CAUSE	REMEDY
Uneven Till	Tiller not level right to left	Adjust skids for same depth Adjust tractor lower lift arms
Noisy	Loose components Low oil in gearbox	Check all bolts for tightness. Refer to Torque Specs Check for proper oil level. Refer to Lubrication Section
Knocking or Chattering	Tiller is tilted towards the rear	Adjust 3-point hitch top link to level tiller
Bogging	Tractor engine speed too slow Ground speed too fast Vines wrapped around rotor	Increase engine speed to 540 PTO rpm Use lower tractor gear Remove vines
Loose Chain	Chain worn beyond self-adjusting capacity	Have dealer service chain

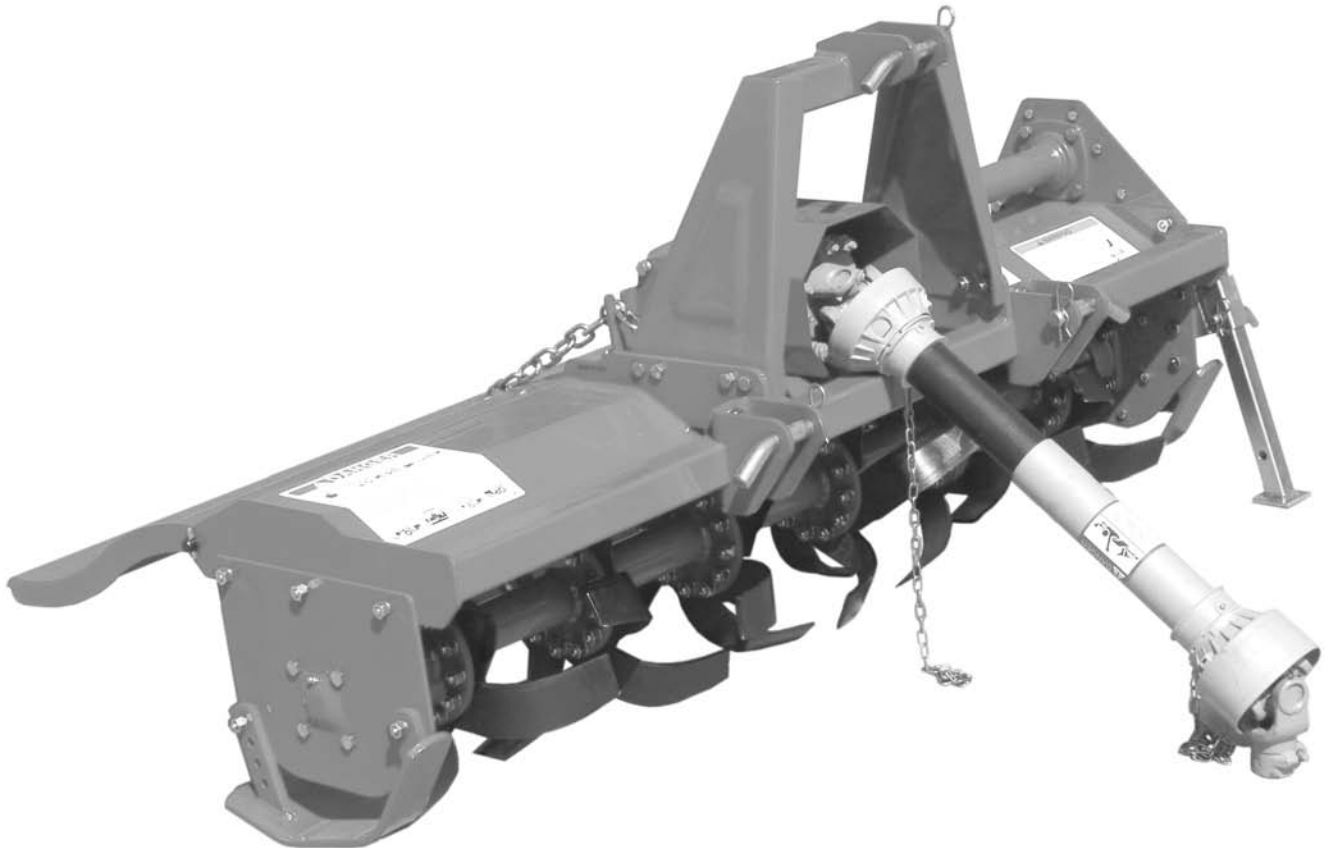

SECTION V DEALER ASSEMBLY

WARNING

THE FOLLOWING SAFETY PRECAUTIONS SHOULD BE THOROUGHLY UNDERSTOOD BEFORE ATTEMPTING MACHINE ASSEMBLY

1. Wear personal protective equipment such as, but not limited to, protection for eyes, ears, feet, hands and head when operating or repairing the equipment. Do not wear loose clothing or jewelry that may catch on equipment moving parts.
2. Do not lift heavy parts or assemblies. Use crane, jack, tackle, fork trucks or other mechanical devices.
3. Select an area for assembly that is clean and free of any debris which might cause persons working on the assembly to trip.
4. Arrange parts to be assembled neatly in the work area and have tools or other mechanical assisting devices in easy reach.
5. Inspect all parts and assemblies thoroughly and remove any sharp edges, grease, oil, or dirt which might cause pieces to slip when handling.
6. Preview the assembly instructions in your operator's manual before proceeding further.
7. If the assembly instructions call for parts or assemblies to be blocked up, use only blocking material that is in good condition and is capable of handling the weight of the assembly to be blocked. Also insure that the blocking material is on a clean, dry surface.
8. Never put hands or any other part of body under blocked up assemblies if at all possible.
9. Always wear goggles or safety glasses when hammering, grinding or drilling metal parts.
10. If the assembly calls for welding or cutting, be sure that there are no flammable materials close at hand and that bystanders have taken necessary precautions.

AFTER COMPLETING ANY ASSEMBLY STEP, THOROUGHLY READ THE NEXT STEP IN THE ASSEMBLY INSTRUCTIONS BEFORE PROCEEDING WITH THAT STEP.

11. After completing assembly, thoroughly inspect the machine to be sure that all nuts, bolts, or any other fastened assemblies have been thoroughly tightened. (Refer to Torque Specifications, page 17)
12. After completing assembly, be sure that all safety locking devices or guards are in place.
13. Before operating the machine, thoroughly read the operation section of this manual.
14. Before operating, read the maintenance section of this manual to be sure that any parts requiring lubrication such as gearboxes are full to avoid any possible damage.

BEFORE OPERATING THE EQUIPMENT, IF YOU HAVE ANY QUESTIONS REGARDING THE PROPER ASSEMBLY OR OPERATION, CONTACT YOUR AUTHORIZED BUSH HOG DEALER OR REPRESENTATIVE.

NOTICE: Refer to Figures 1-1, 3-1, 4-1 and 5-1 for visual reference to aid assembly.

A. The parking stand is shipped installed in the upside down position. Remove the stand and replace it in the correct position. Pin into the "parked" position.

B. Place the slip clutch shield support plate against the front of the gearbox and fasten with (4) M8 x 16mm bolts and lockwashers .

C. Remove the cross bolt from the end of the slip clutch. Slide the slip clutch onto the gearbox input shaft and align the cross bolt hole with the groove in the input shaft. Replace the cross bolt and tighten securely .

D. Position the slip clutch shield over the support plate and fasten into position with (3) M8 x 16mm bolts and lockwashers.

E. Place the "A" frame weldment into position against the strongbacks on the main frame and fasten with (8) M10 x 35mm bolts and flanged locknuts.

F. Place lower hitch pin brackets on front cross member of frame and fasten into position using M12 U-bolts and flanged locknuts. Notice that the hitch pin brackets can be positioned to best match the lift arms on your particular tractor.

G. Attach one end of rear deflector adjustment chain to rear deflector with the clevis provided. The other end will fit into the slot next to the gearbox.

IMPORTANT

Before delivery to customer, perform SLIP CLUTCH OPERATIONAL CHECK as described in Section 4-4, page 11.

NOTE

It is important that the customer receives this operator's manual with his machine. Safe and satisfactory performance of this machine depends on the operator knowing the correct operating and maintenance procedures. The customer should be reminded to fill out and mail in the warranty registration card within ten days of purchase.

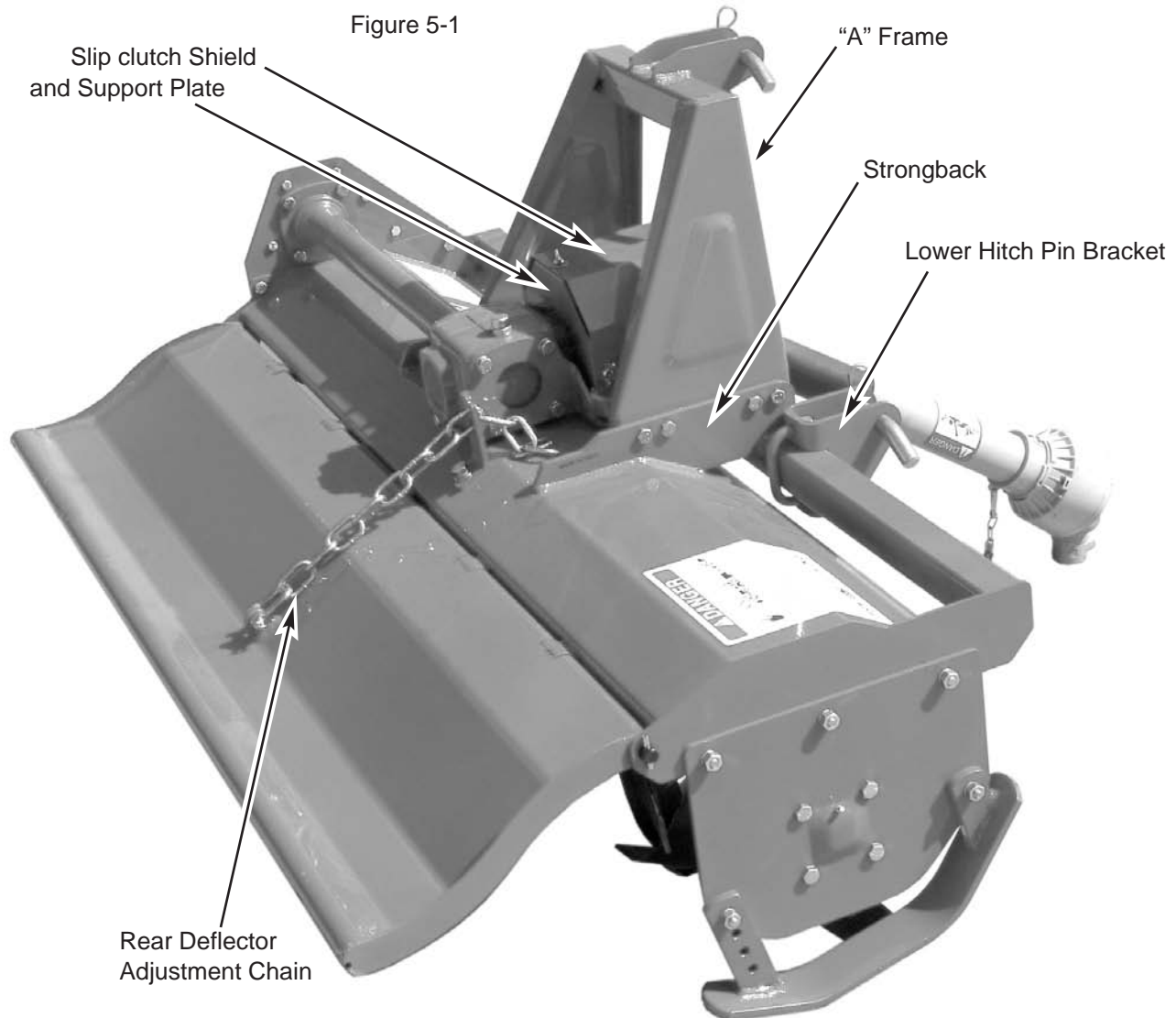

SAFETY DECALS

To promote safe operation, Bush Hog supplies safety decals on all products manufactured. Because damage can occur to safety decals either through shipment, use or reconditioning, Bush Hog will, upon request, provide safety decals for any of our products in the field at no charge. Contact your authorized Bush Hog dealer for more information.

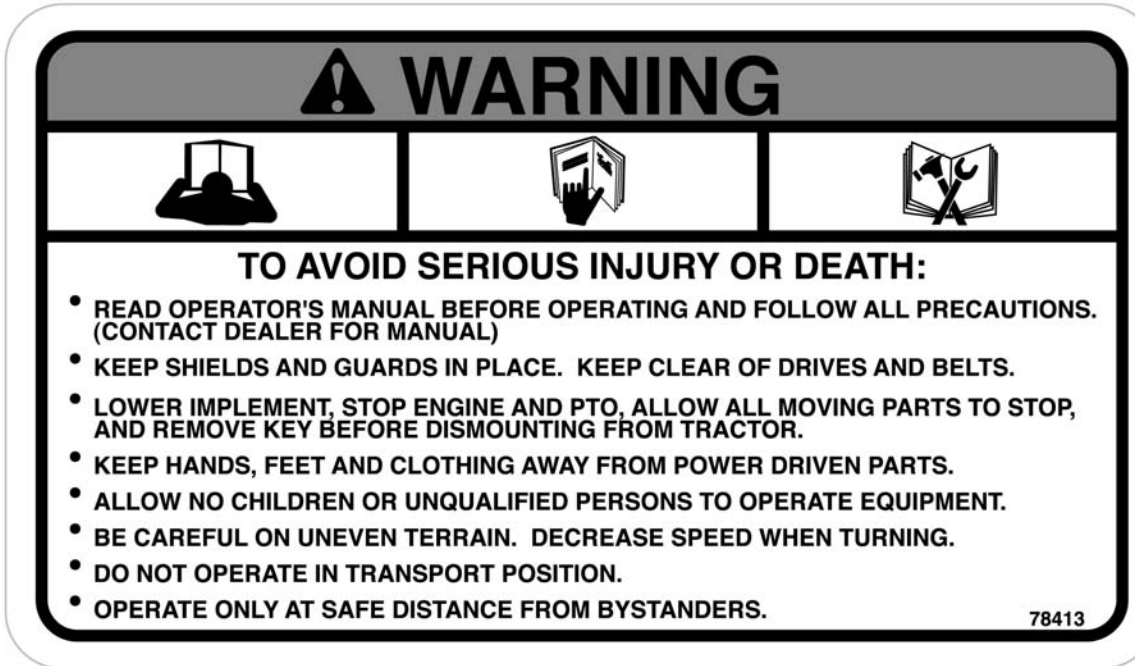

Part No. 78413



Part No. 81067



Part No. 50042281

TORQUE SPECIFICATIONS

Proper torque for American fasteners used on Bush Hog equipment.
Recommended Torque in Foot Pounds (Newton Meters).*

AMERICAN

Bolt Head Markings

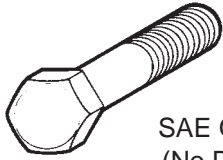

SAE Grade 2
(No Dashes)

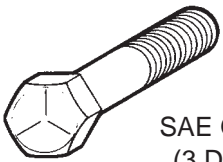

SAE Grade 5
(3 Dashes)

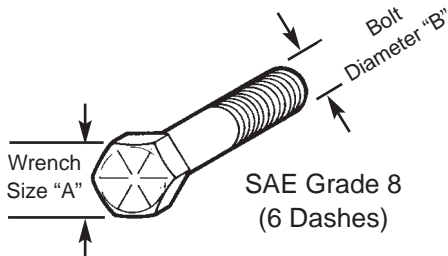

SAE Grade 8
(6 Dashes)

WRENCH SIZE (IN.) "A"	BOLT DIAMETER (IN.) "B" AND THREAD SIZE	SAE GRADE 2	SAE GRADE 5	SAE GRADE 8
7/16	1/4 - 20 UNC	6 (7)	8 (11)	12 (16)
7/16	1/4 - 28 UNF	6 (8)	10 (13)	14 (18)
1/2	5/16 - 18 UNC	11 (15)	17 (23)	25 (33)
1/2	5/16 - 24 UNF	13 (17)	19 (26)	27 (37)
9/16	3/8 - 16 UNC	20 (27)	31 (42)	44 (60)
9/16	3/8 - 24 UNF	23 (31)	35 (47)	49 (66)
5/8	7/16 - 14 UNC	32 (43)	49 (66)	70 (95)
5/8	7/16 - 20 UNF	36 (49)	55 (75)	78 (106)
3/4	1/2 - 13 UNC	49 (66)	76 (103)	106 (144)
3/4	1/2 - 20 UNF	55 (75)	85 (115)	120 (163)
7/8	9/16 - 12 UNC	70 (95)	109 (148)	153 (207)
7/8	9/16 - 18 UNF	79 (107)	122 (165)	172 (233)
15/16	5/8 - 11 UNC	97 (131)	150 (203)	212 (287)
15/16	5/8 - 18 UNF	110 (149)	170 (230)	240 (325)
1-1/8	3/4 - 10 UNC	144 (195)	266 (360)	376 (509)
1-1/8	3/4 - 16 UNF	192 (260)	297 (402)	420 (569)
1-5/16	7/8 - 9 UNC	166 (225)	430 (583)	606 (821)
1-5/16	7/8 - 14 UNF	184 (249)	474 (642)	668 (905)
1-1/2	1 - 8 UNC	250 (339)	644 (873)	909 (1232)
1-1/2	1 - 12 UNF	274 (371)	705 (955)	995 (1348)
1-1/2	1 - 14 UNF	280 (379)	721 (977)	1019 (1381)
1-11/16	1-1/8 - 7 UNC	354 (480)	795 (1077)	1288(1745)
1-11/16	1-1/8 - 12 UNF	397 (538)	890 (1206)	1444 (1957)
1-7/8	1-1/4 - 7 UNC	500 (678)	1120 (1518)	1817 (2462)
1-7/8	1-1/4 - 12 UNF	553 (749)	1241 (1682)	2013 (2728)
2-1/16	1-3/8 - 6 UNC	655 (887)	1470 (1992)	2382 (3228)
2-1/16	1-3/8 - 12 UNF	746 (1011)	1672 (2266)	2712 (3675)
2-1/4	1-1/2 - 6 UNC	870 (1179)	1950 (2642)	3161 (4283)
2-1/4	1-1/2 - 12 UNF	979 (1327)	2194 (2973)	3557 (4820)

METRIC

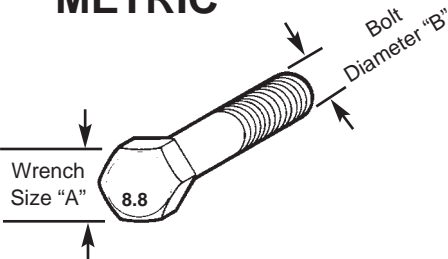

Numbers appearing on bolt heads indicate ASTM class.

Proper torque for metric fasteners used on Bush Hog equipment.
Recommended torque in foot pounds (newton Meters).*

WRENCH SIZE (mm) "A"	BOLT DIA. (mm) "B"	ASTM 4.6	ASTM 8.8	ASTM 9.8	ASTM 10.9
8	5	1.8 (2.4)		5.1 (6.9)	6.5 (8.8)
10	6	3 (4)		8.7 (12)	11.1 (15)
13	8	7.3 (10)		21.1 (29)	27 (37)
16	10	14.5 (20)		42 (57)	53 (72)
18	12	25 (34)	74 (100)	73 (99)	93 (126)
21	14	40 (54)	118 (160)	116 (157)	148 (201)
24	16	62 (84)	167 (226)	181 (245)	230 (312)
30	20	122 (165)	325 (440)		449 (608)
33	22		443 (600)		611 (828)
36	24	211 (286)	563 (763)		778 (1054)
41	27		821 (1112)		1138 (1542)
46	30	418 (566)	1119 (1516)		1547 (2096)

*Use 75% of the specified torque value for plated fasteners. Use 85% of the specified torque values for lubricated fasteners.

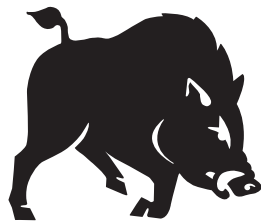

BUSH HOG[®]
Performance You Can Count OnSM

P.O. Box 1039 • Selma, AL 36702-1039
Telephone (334) 874-2700 • www.bushhog.com